

2 & 3 Door Siphon Installation Instructions

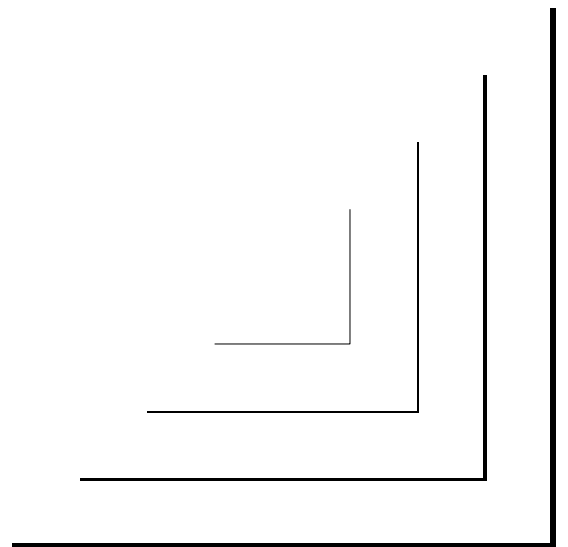

Door Siphon System

System Facilities

- Only one door to be released electrically at any one time.
- A door controller at each door (up to eight doors) to facilitate a single point Connection of all cables from the door.
- Single data cable to each door controller, ran in daisy chain configuration.
- Call button operates audio indication at the console, additional facility to have an extension bell connected from the main control panel.
- Call button operates a visual indicator on the console to indicate which door is calling.
- Visual indicators at the call and release points to indicate the electrical release of the electric door stick/lock.
- Door opened monitored
- Electric door lock/strike monitored.
- Night Key facility to allow re-entry into the system by an authorised user.

System Configuration

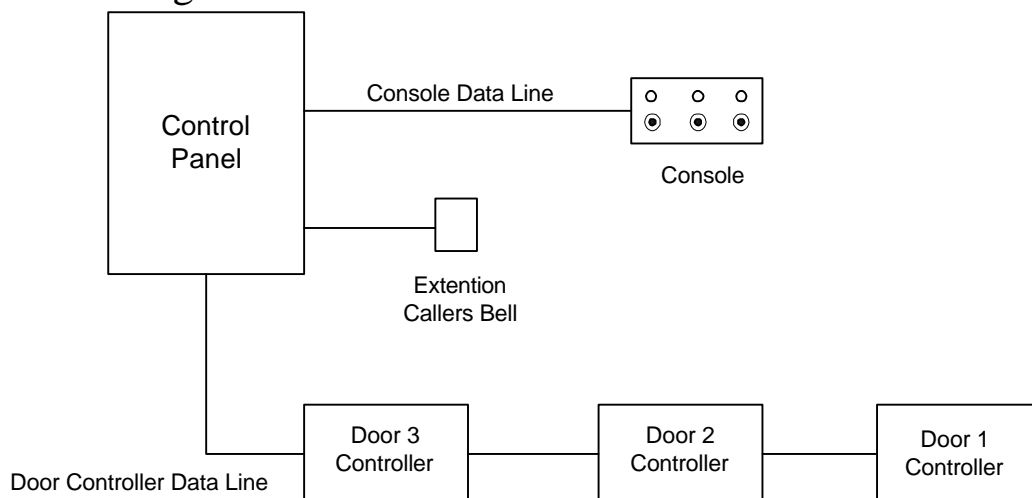

fig.1

Installing the System

Control Panel

The control panel contains a mains power supply. The mains supply should be switched off before opening the door of the control unit.

The Control Panel is to be located within the secure area, and connected to a 1 Amp unswitched fused spur.

There are two Printed Circuit Boards in the control box. The upper PCB is the power supply and the lower is the main PCB controller.

The relay on the control PCB operates whenever a 'Call' switch is activated. This may be connected to a sounder or bell to alert the operator. The sounder may be powered from the system power supply via the unused 'OUT' terminals on the power supply.

Door Controllers

The Door Controllers are co-located on the secure side of each of the doors.

Data cabling from the Control Panel to both the Door Controllers and the Console is in 6 core screened cable.

Cabling from the Control Panel to the Door Controllers is ran in daisy chain configuration.

Door 1 being the last door on the Door Controller chain.

Fig. 2 shows the wiring schedule for a 2 door siphon, and fig. 3 a 3 door siphon.

Fig. 5 shows the detailed connections from the door furniture to the Door Controller. Cables from the Door Controllers to the door furniture may be in standard alarm cable.

Console Unit

The Console is connected by a 6 core data cable to the Control Panel, wiring details are shown in fig. 2 and fig.3 Wiring Schedules.

Additional Consoles may be fitted if required.

NB

Data cable screens are connected throughout and earthed at the control panel only.

2 Door Siphon System Data Cable Wiring Schedule

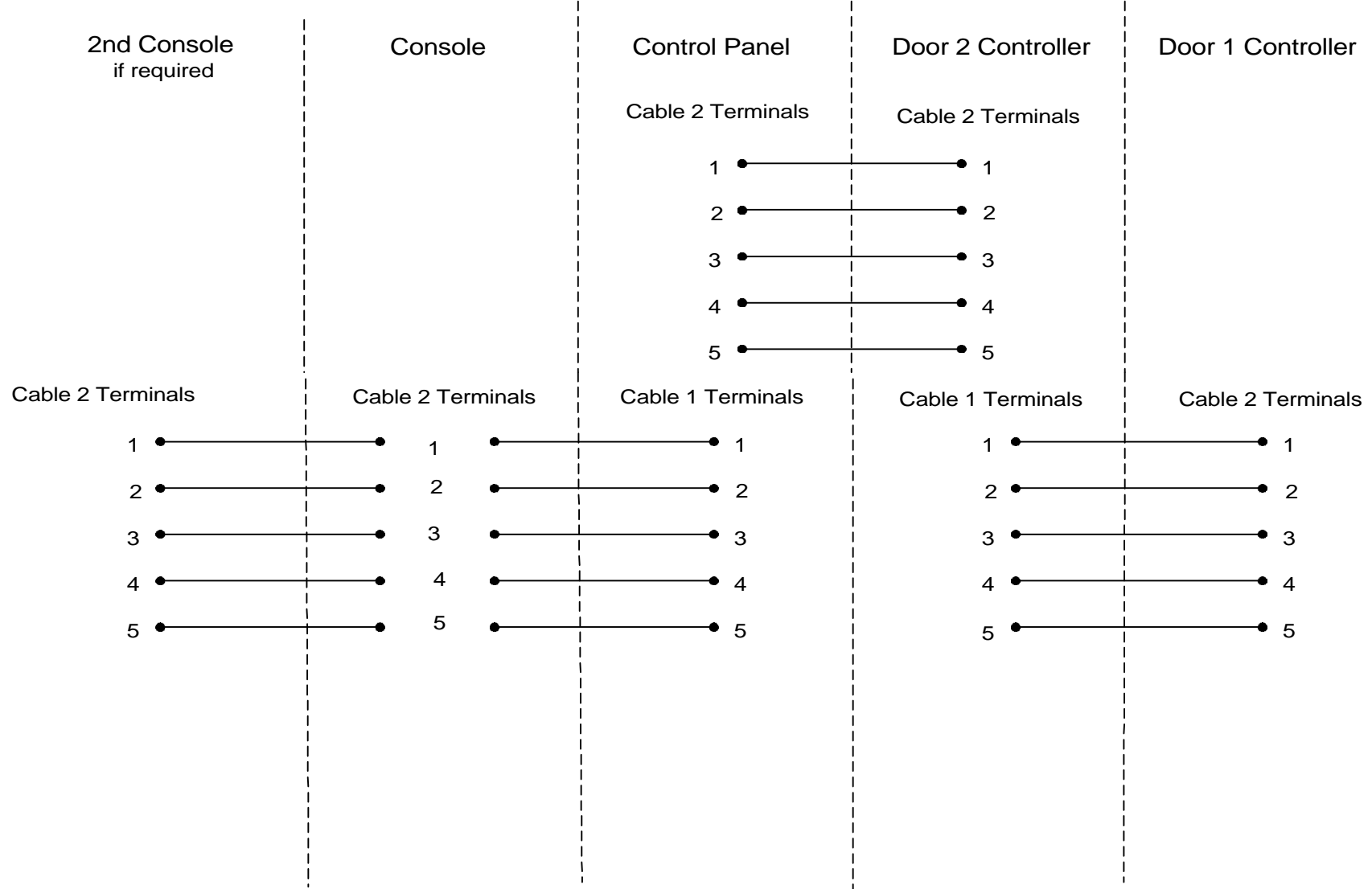

fig.2

3 Door Siphon System Data Cable Wiring Schedule

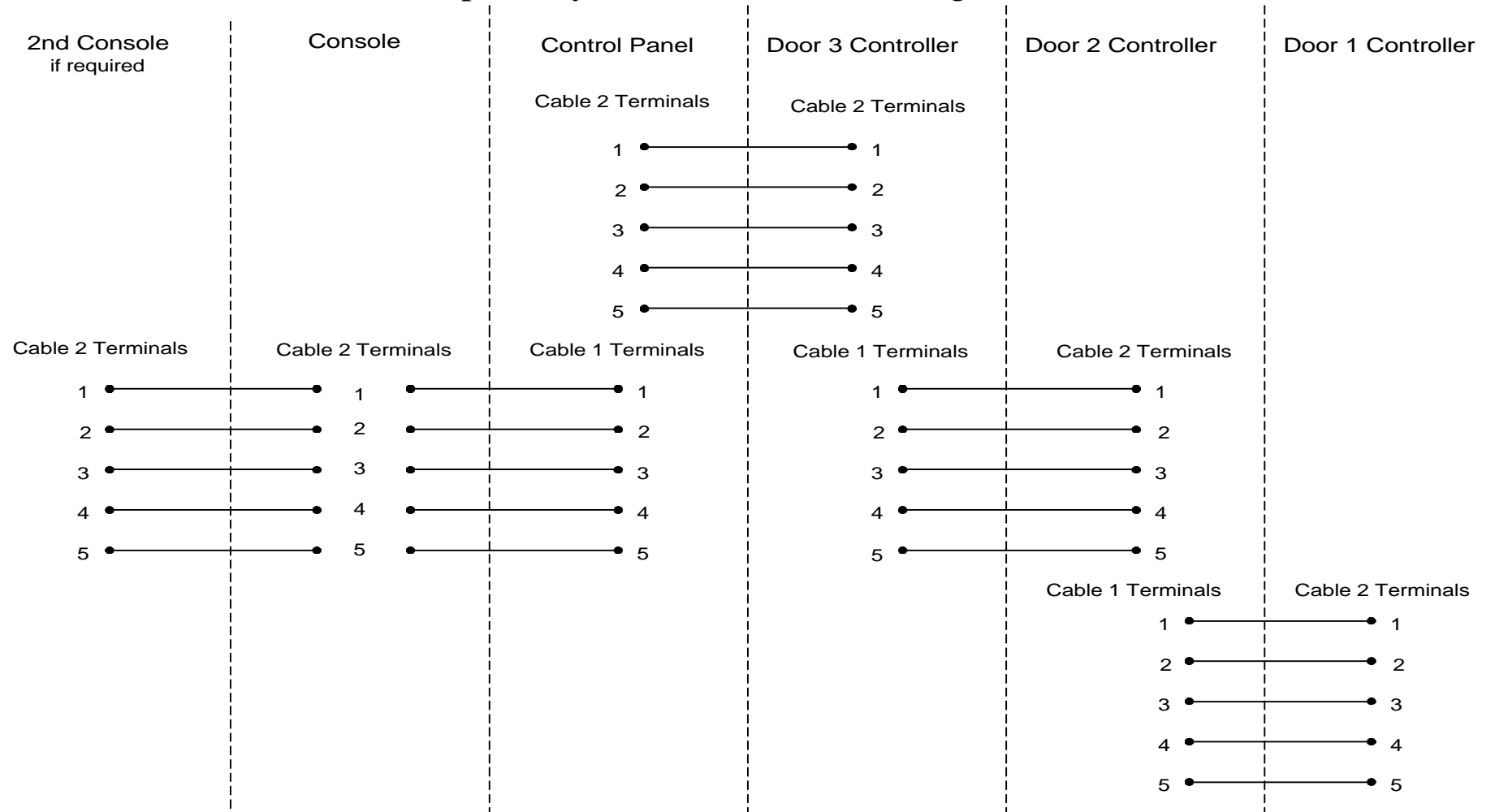

fig.3

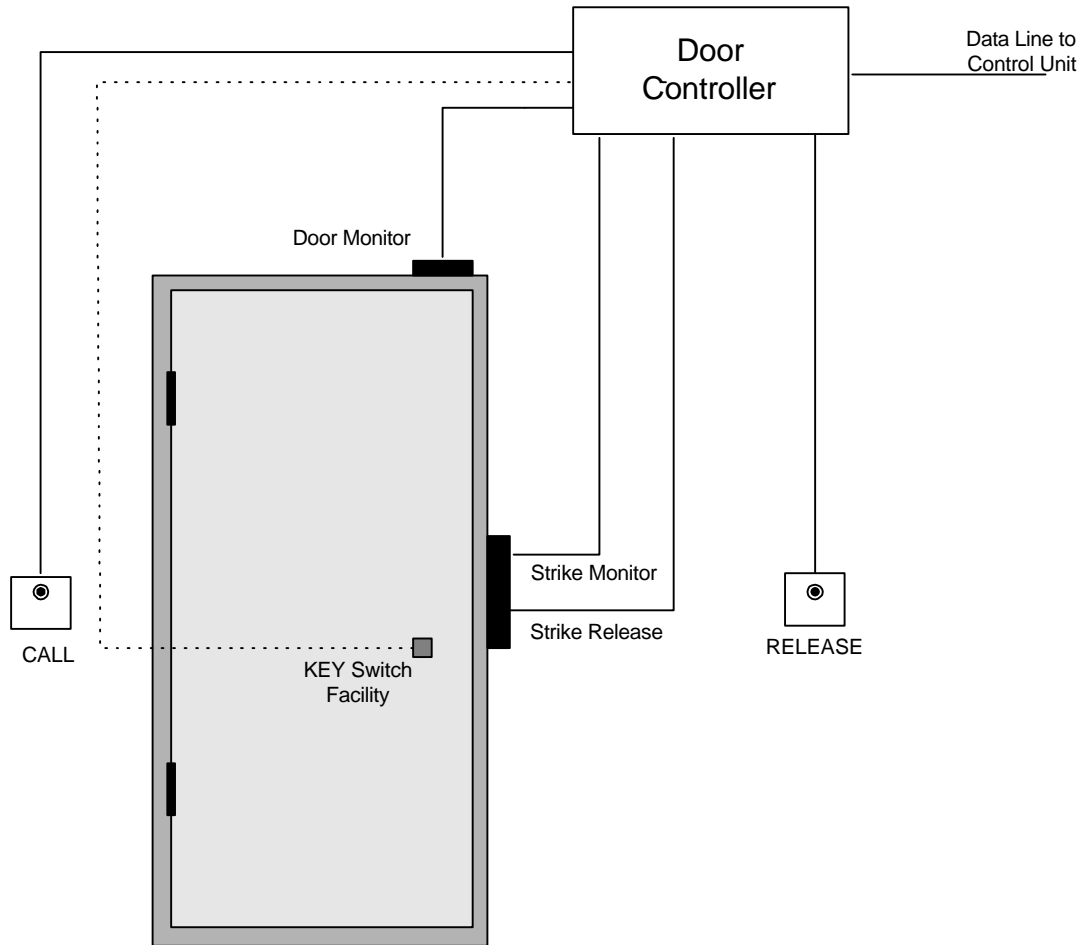

fig.4

Each door has a Door Controller co-located, to facilitate a single point connection for all cabling from the door.

Connections to Door Controller:

- Call attendant
- Request to exit.
- Electric Strike/lock release (voltage free contacts 1 Amp rated).
- Door contacts monitor.
- Strike/lock monitor.
- Visual indication for user that door lock has been released.
- Key Switch facility (Door 1 of system).

Detailed Connections at the Door Controller

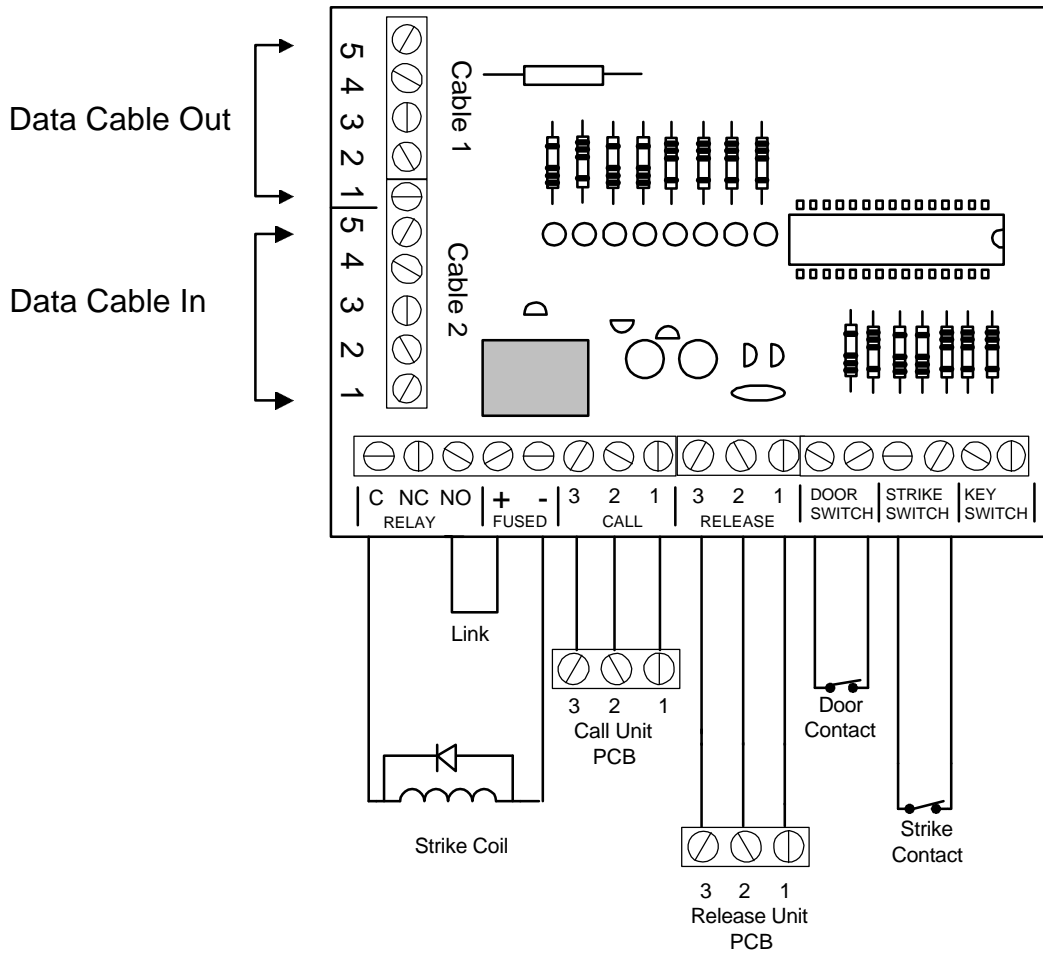

fig. 5

NB

fig1 shows wiring to an electric lock that is fail secure.

The diode supplied with the Door Controller is a back-EMF suppression diode and should be fitted as shown.

The terminals marked 'key Switch' are only used on Door 1 if the 'Night Key' facility is required.

The fused output is protected by a thermal fuse, which resets itself after the fault is removed.

Diagnostics

The Door Controller, Control Panel and Cosole have on board indicators which may be used to help isolate wiring faults. Fig 6 shows the position of the LED's.

Each LED is updated each time a batch of data is received from the Control box. If the data lines are not connected then no update will be made and the LED's will freeze in their last status.

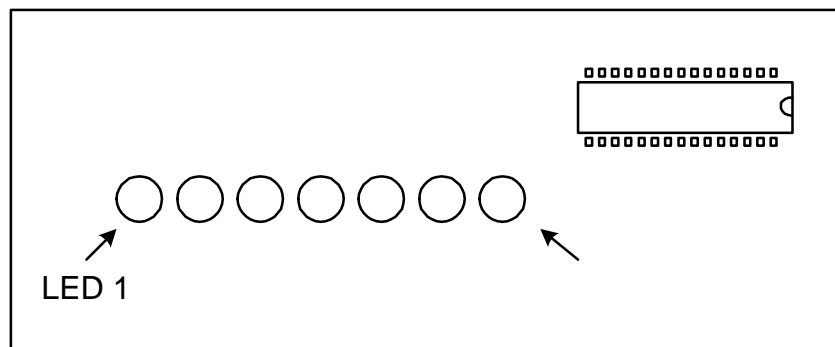

Door Controller LED Functions:

Led is permanently illuminated, it is likely that a bad connection on terminals 3, 4 or 5 is to blame. If it flickers then the problem is likely to be from some sort of interference.

flash depends on the number of doors on the system, the more doors the slower the LED will flash. If it is extinguished or permanently illuminated then there will be either a

LED 3: Shows the status of the Call switch. LED off indicates the switch is normal, LED on indicates that the button is pressed.

LED on indicates that the button is pressed.

LED 5: Shows the status of the door switch. LED off indicates the door is open, LED on

LED 6: Shows the status of the door strike contacts. LED off indicates the door strike is operated, LED on indicates that the door is normal (i.e. not operated).

LED 7: Shows the status of the lock contacts. LED off indicates the door is unlocked, LED on indicates that the door is locked.

Control Panel LED Functions:

The diagnostic LED's may be disabled by removing the link which is located just below the LED's.

Each LED is updated each time a batch of data is sent from the Control box.

The function of each LED is as follows:

LED 1: Not used.

LED 2 : This flashes when data is being sent from the Control box. The speed of the flash depends on the number of doors on the system, the more doors the slower the LED will flash.

LED 3: Shows the status of the Call switches. LED off indicates that all of the switches are normal, LED on indicates that one or more buttons are pressed.

LED 4: Shows the status of the Release switch. LED off indicates that all of the switches are normal, LED on indicates that one or more buttons are pressed.

LED 5: Shows the status of the door switch. LED off indicates that all of the doors are closed, LED on indicates that one or more doors are open.

LED 6: Shows the status of the door strike contacts. LED off indicates that all of the door strikes are normal (i.e. not operated), LED on indicates that the one or more of the door strikes are operated.

LED 7: Shows the status of the lock contacts. LED off indicates that all the doors are unlocked, LED on indicates that one or more of the doors are locked.

Console LED Functions:

Only LED 7 is used on the Console. This flashes when data is being received from the Control box. The speed of the flash depends on the number of doors on the system, the more doors the slower the LED will flash. If it is extinguished or permanently illuminated then there will be either a problem on terminal 4 or the Control box is not powered.

Phaedrus Limited
Darwen England
01254 774361
E-Mail phaedltd@aol.com